









DEX PRO

Go where other industrial vehicles cannot

Dex Pro is equipped with an affixed trailer, allowing the operator to move materials effortlessly. The size of this carrier makes it easy to maneuver in tight spaces and lets a singular employee cover more ground quickly.

Whether you are attempting to haul heavy objects, a bunch of small boxes, or pick orders, the Dex Pro was designed to help increase efficiency and is perfect for warehouse and manufacturing environments.

FEATURES

-  1,100 lbs (498 kg) capacity, including rider
-  24-volt battery system charges in a 110V outlet
-  Operates up to 30 miles on a full charge
-  Adjustable speed up to 4 mph (6.4 kph)
6 mph option available
-  42.5" (108 cm) turning radius
-  Trailer bed size: 40" x 22" (102 cm x 56 cm)

ADD-ONS



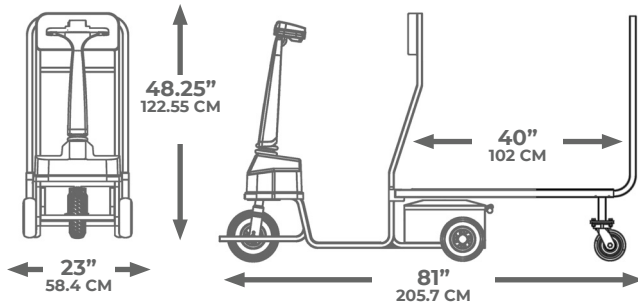

SPECIFICATIONS

Overall dimensions	81" L x 23" W x 48.25" H 205.7cm L x 58.4cm W x 122.5cm H
Deck dimensions	40" L x 22" W (101cm L x 56cm W)
Capacity	1,100 lbs (498 kg) including rider
Speed	Variable 4 mph (6.4 kph) - programmable 6 mph (9.65 kph) option available
Peak power	858 watts/1.15 hp
Battery life	8 hours, 30+ miles
Battery	Two 12-volt / 45 Ah batteries
Battery indicator	5 LED bars to show capacity
Charging times	7 hours @ recommended 50% DOD
Charger DC output	7 amp
Charger AC input	1.5 amp, charges in standard outlet
Turning radius	42.5" (108 cm)
Max incline rating	6° (10.5%) at 50% capacity 4° (7%) at 100% capacity
Frame material	Steel tubing
Tires	9" Rubber, solid foam filled
Rider ergonomics	Padded backrest



HIGHLIGHTS

